

3155/3155i (RM-41), 3152 (RM-61) Schematics - Main PWB

Top Level

Version 1, edit 247

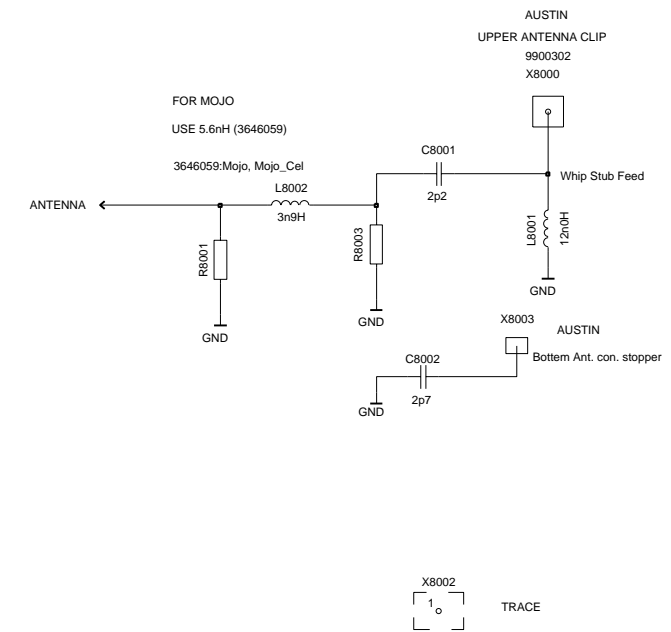
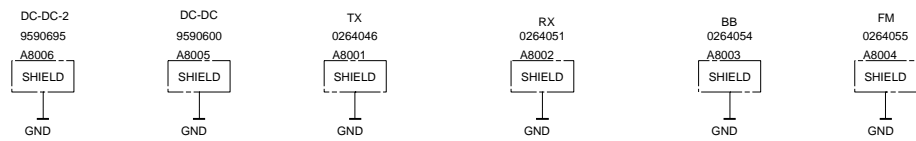
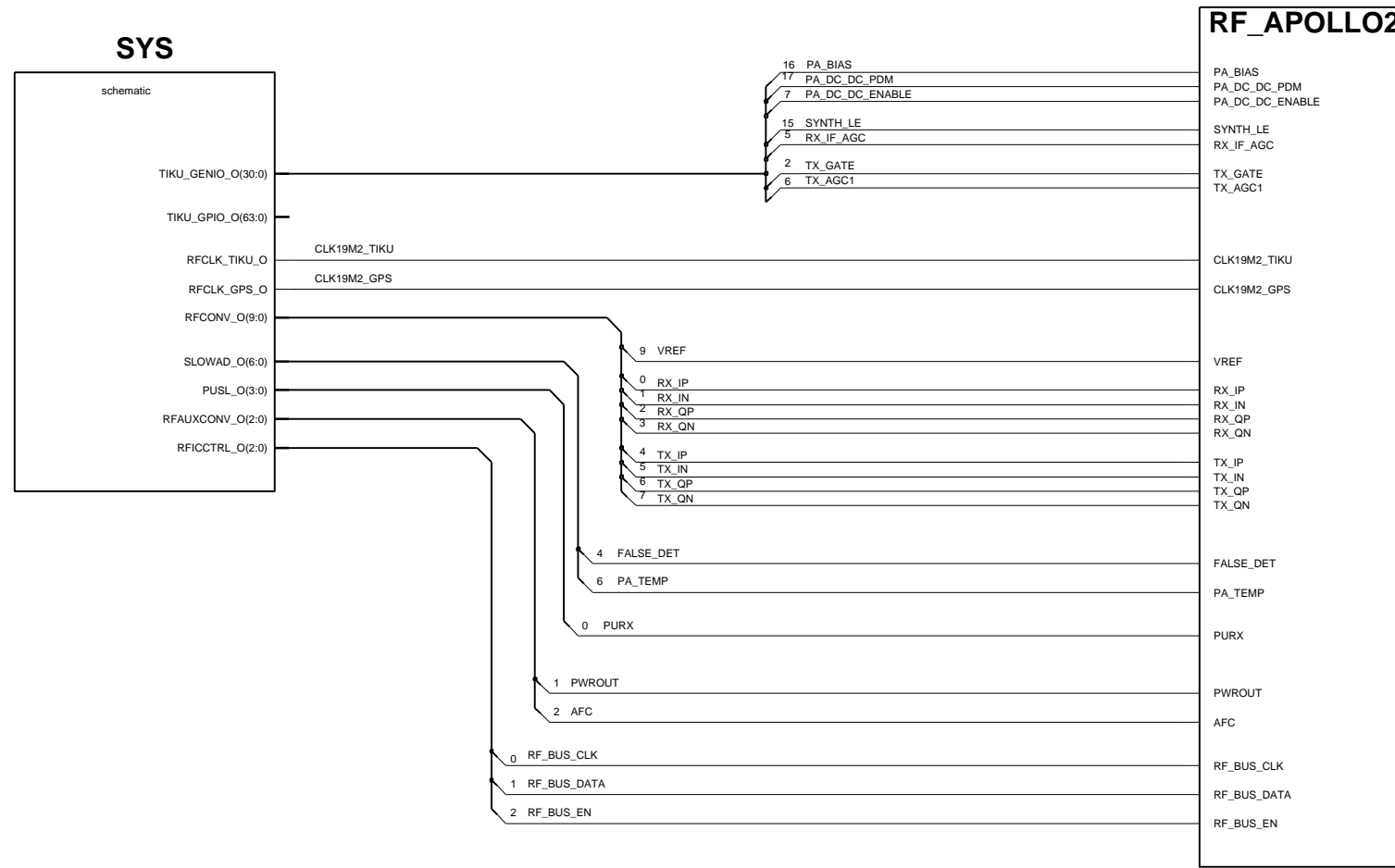

Front End

Version 12, edit 110

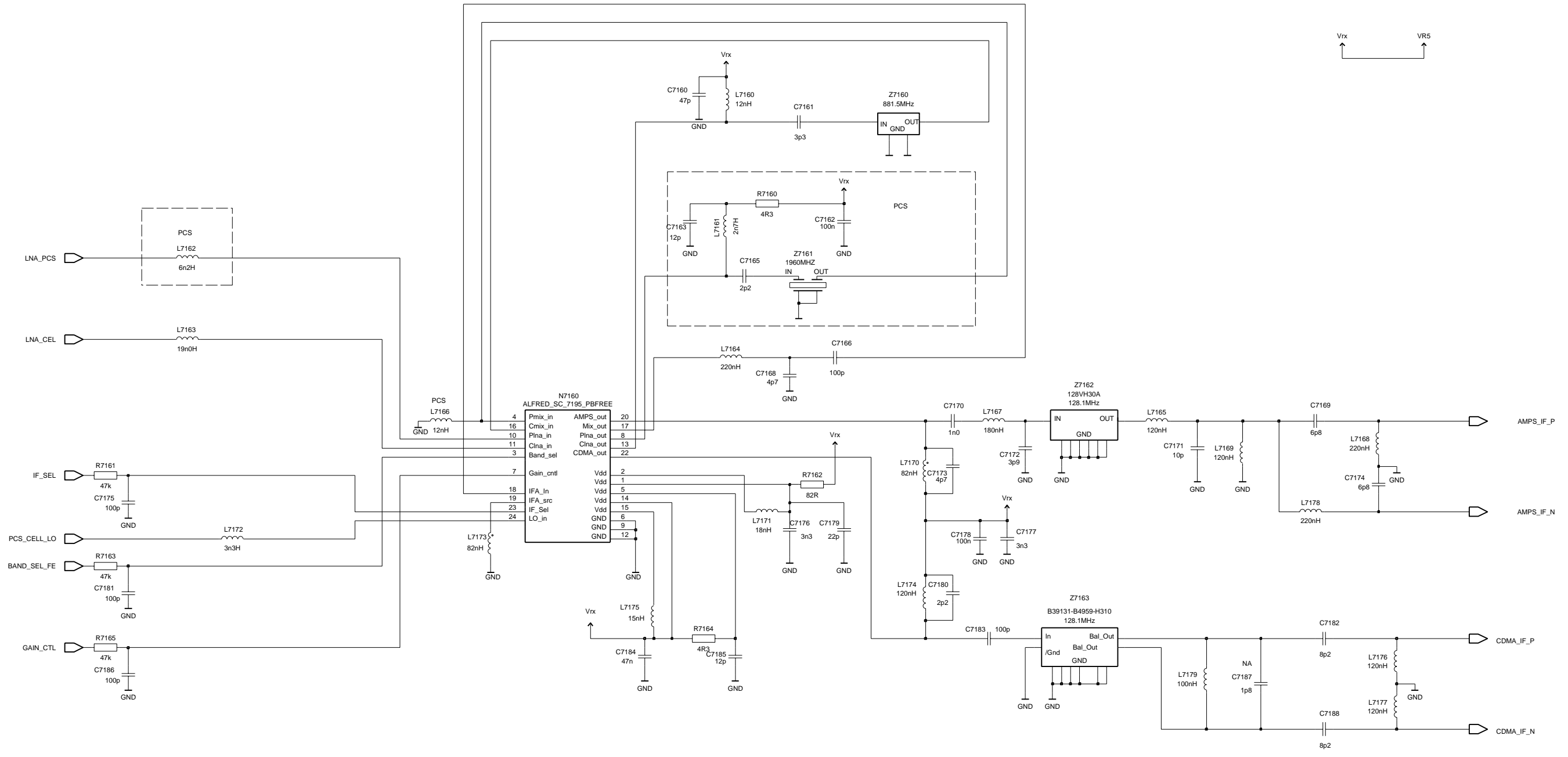

MODES	LOGIC INPUTS		
	BAND	GAIN_CTL	IF_SEL
CEL CDMA Hi Gain	0	1	0
CEL CDMA Lo Gain	0	0	0
PCS CDMA Hi Gain	1	1	0
PCS CDMA Lo Gain	1	0	0
AMPS Hi Gain	0	1	1
AMPS Lo Gain	0	0	1

Audio

Version 1, edit 252

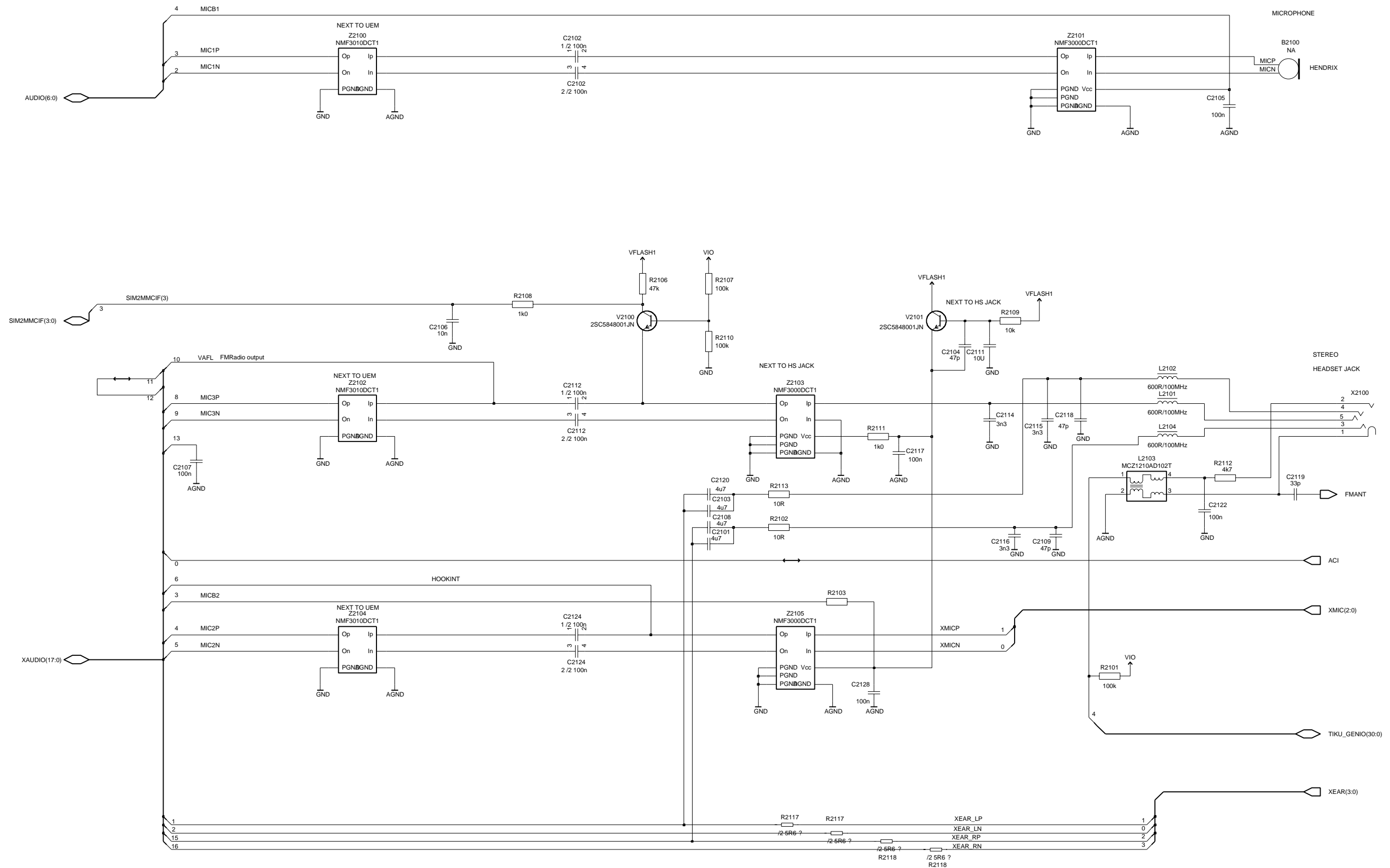

N7100 Rx Downconverter

Version 12, edit 96

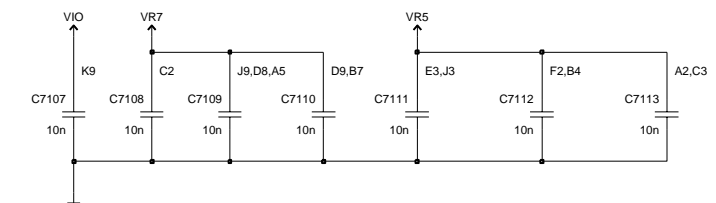
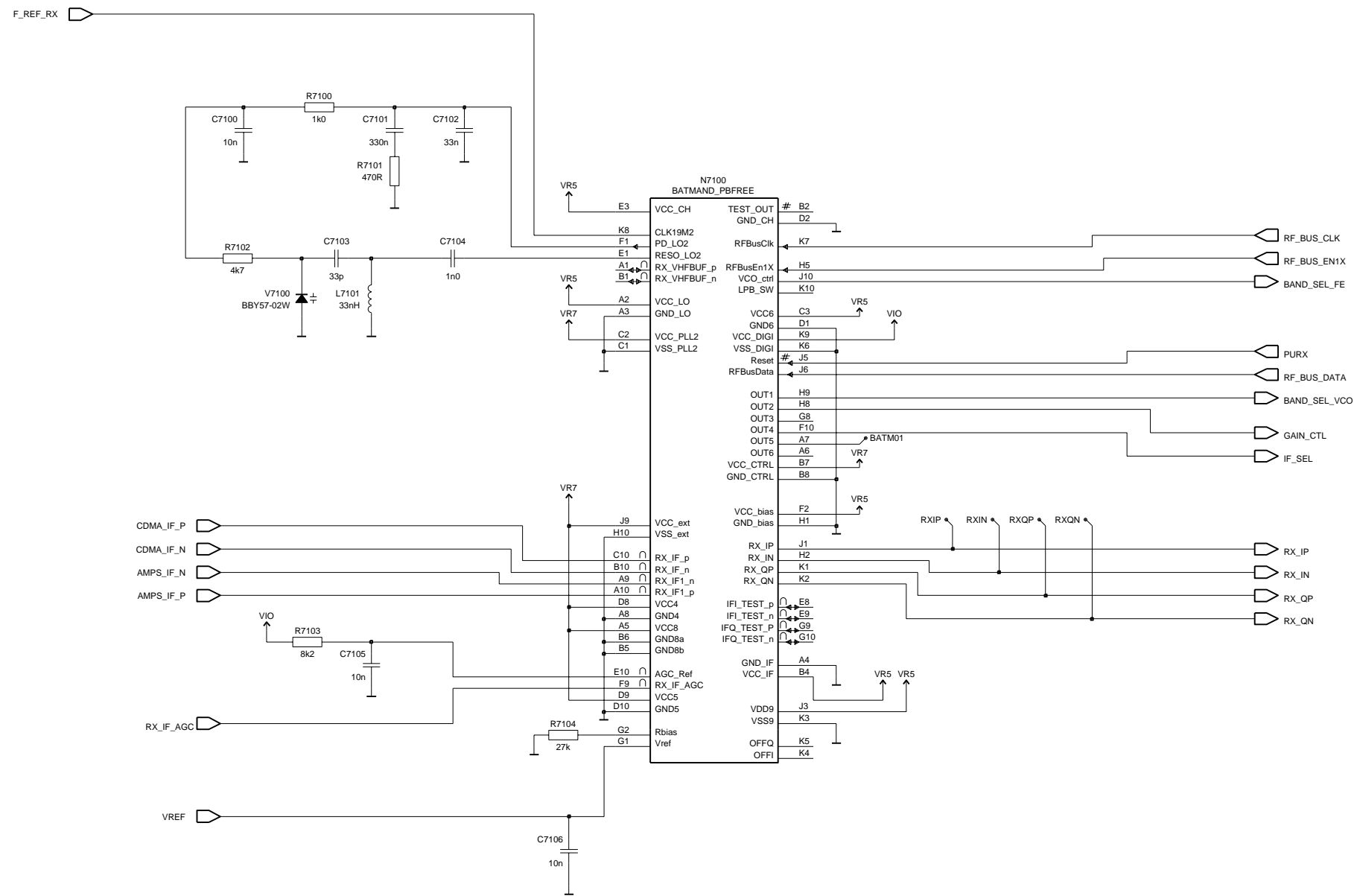

Memory

Version 0.5, edit 214

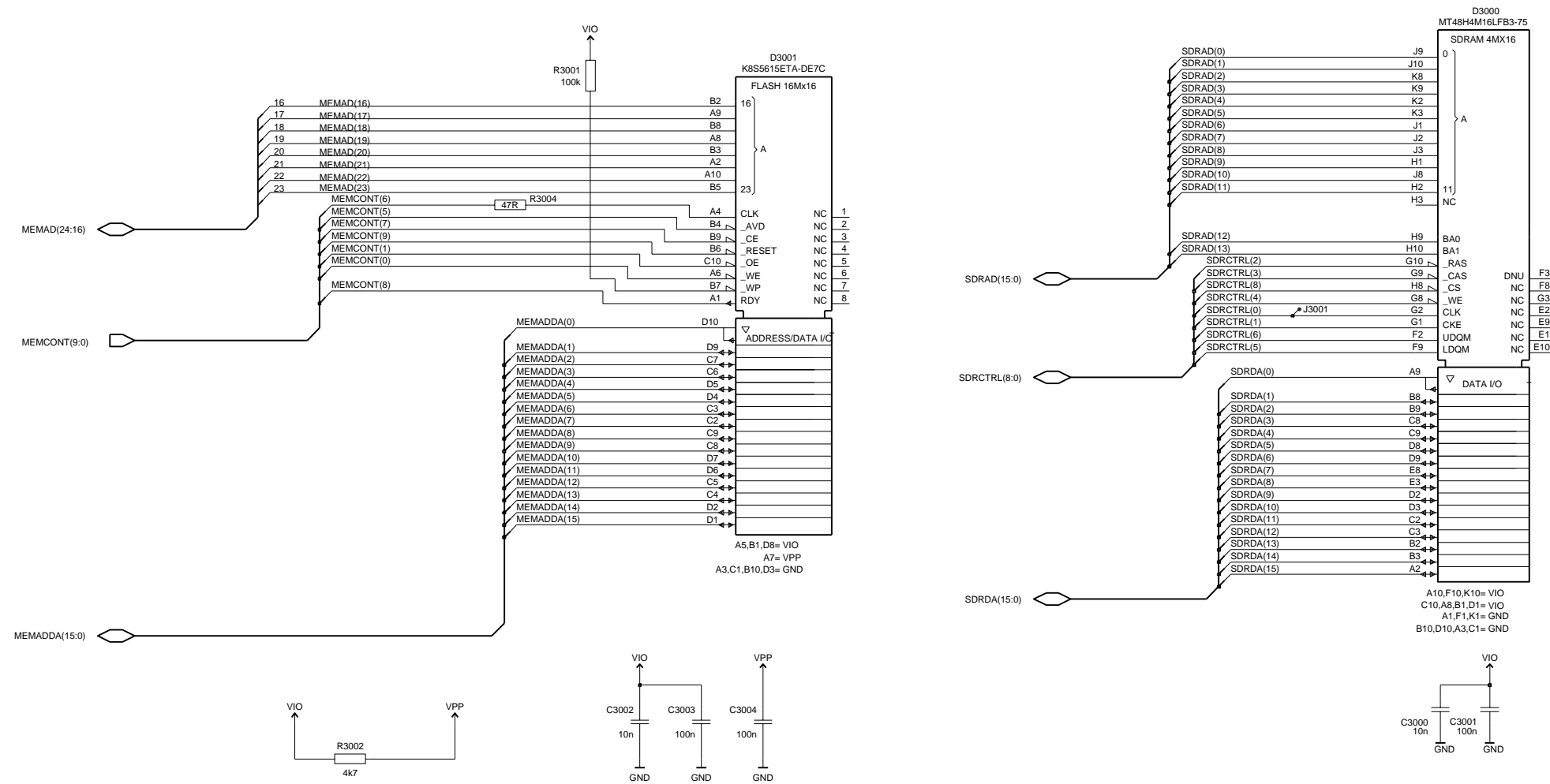

PA

Version 7.5, edit 113

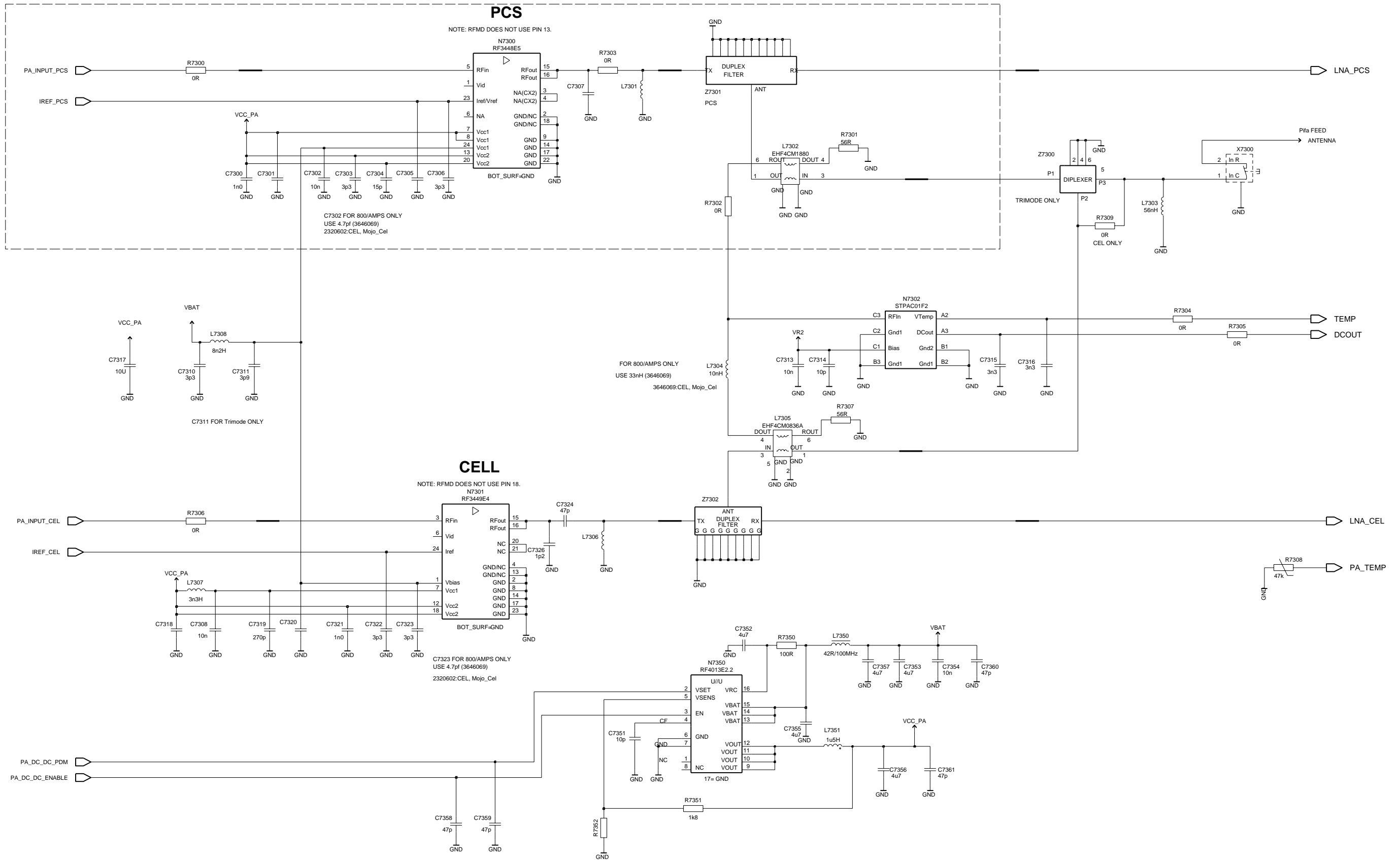

RF-BB Interface

Version 0.5, edit 235

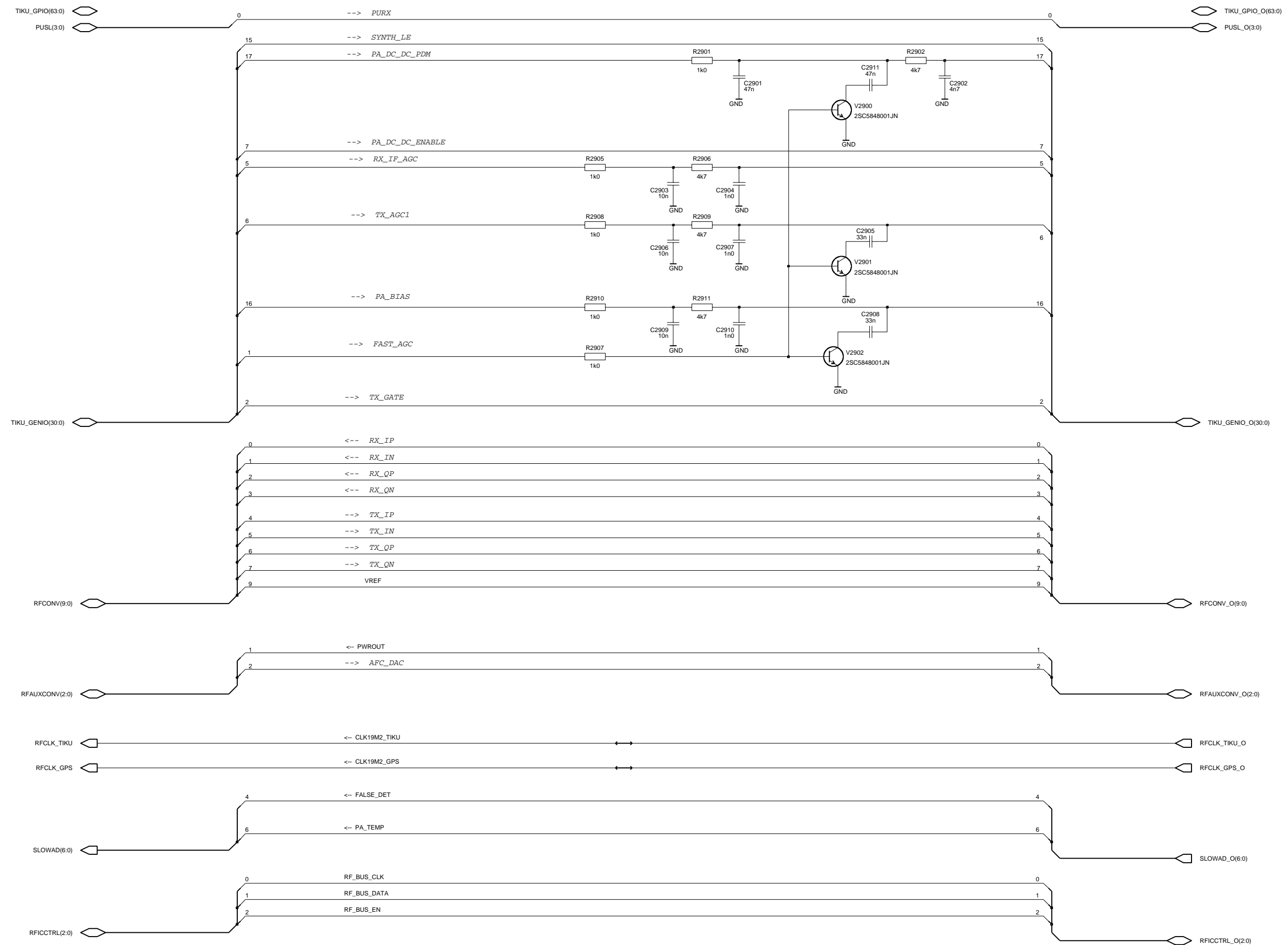

RF - Top

Version 0.5, edit 392

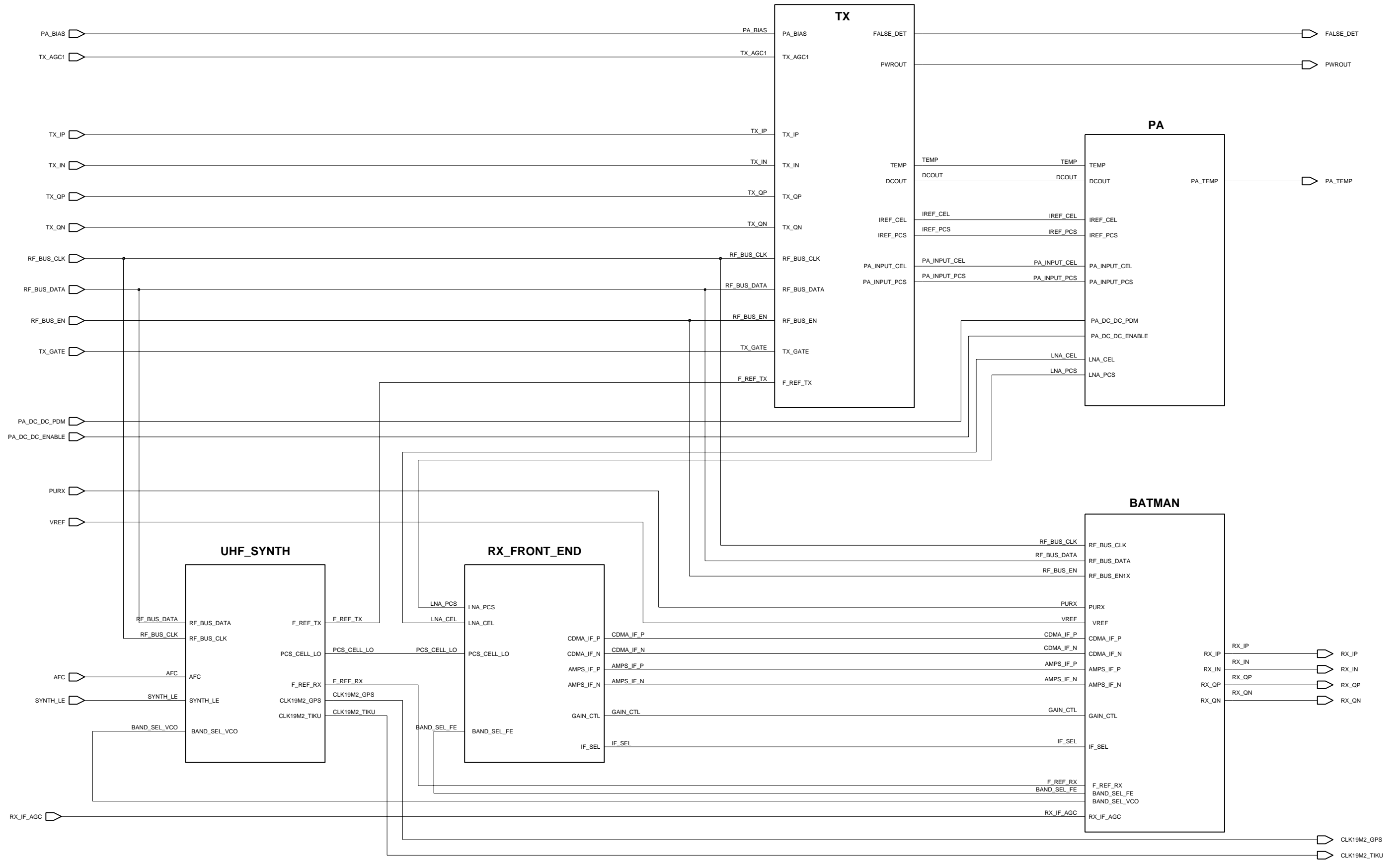

UIM Card Connector

Version 0.0, edit 193

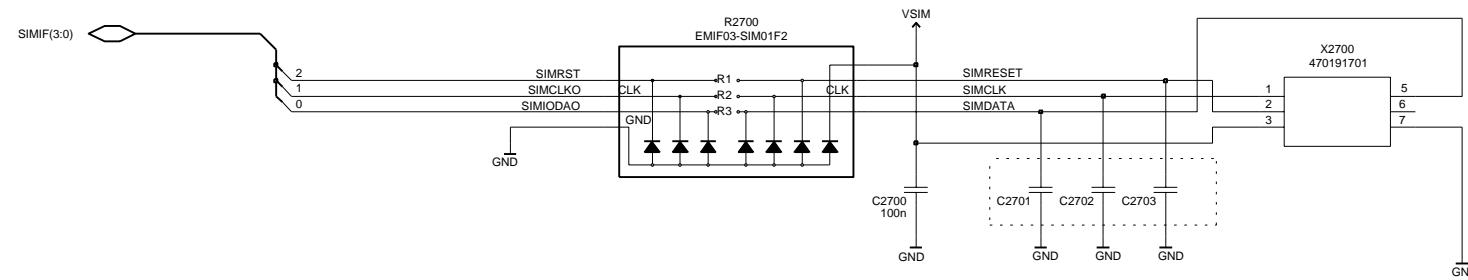

System Connector

Version 0.5, edit 284

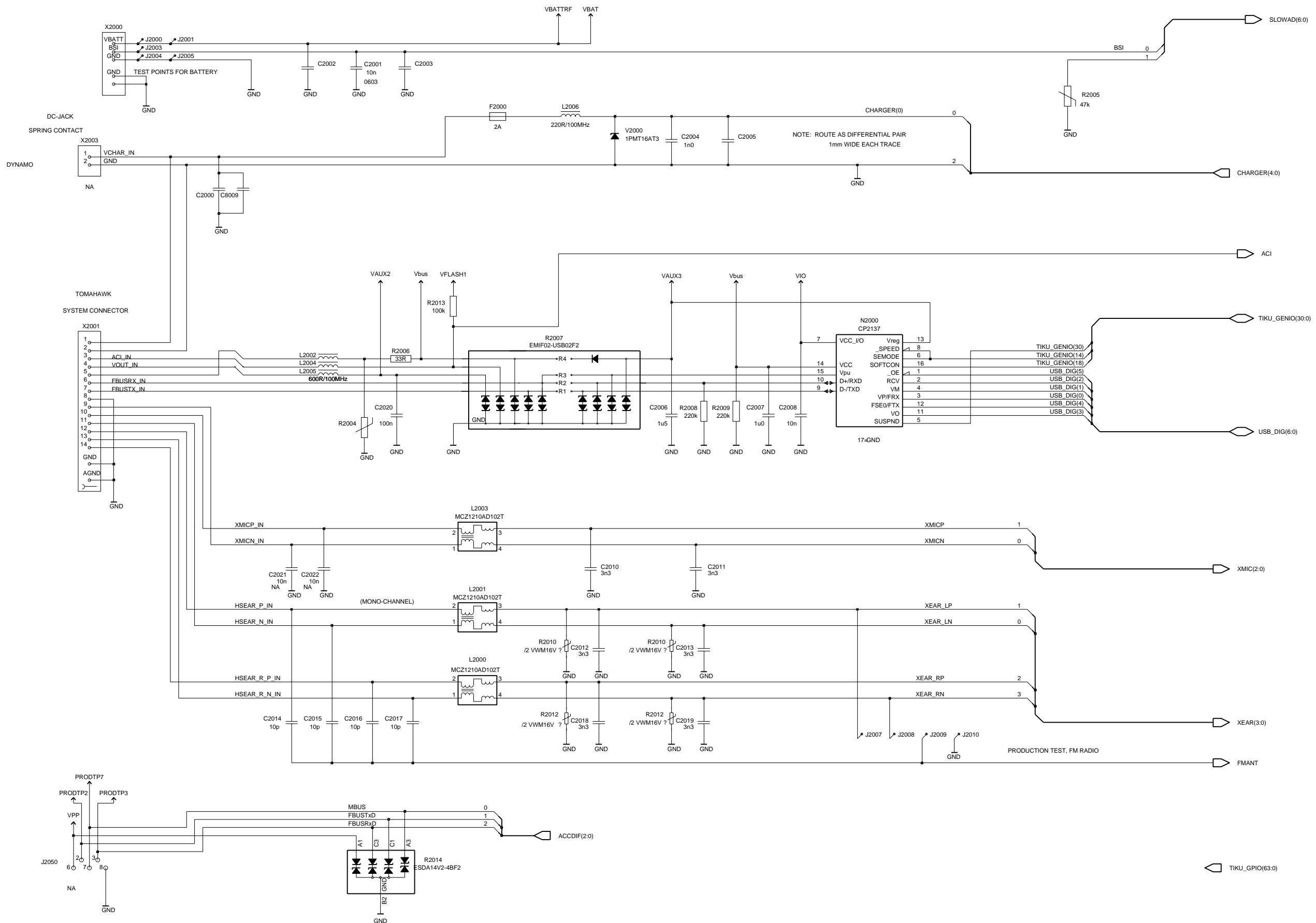

UHF Synthesizer

Version 12, edit 104

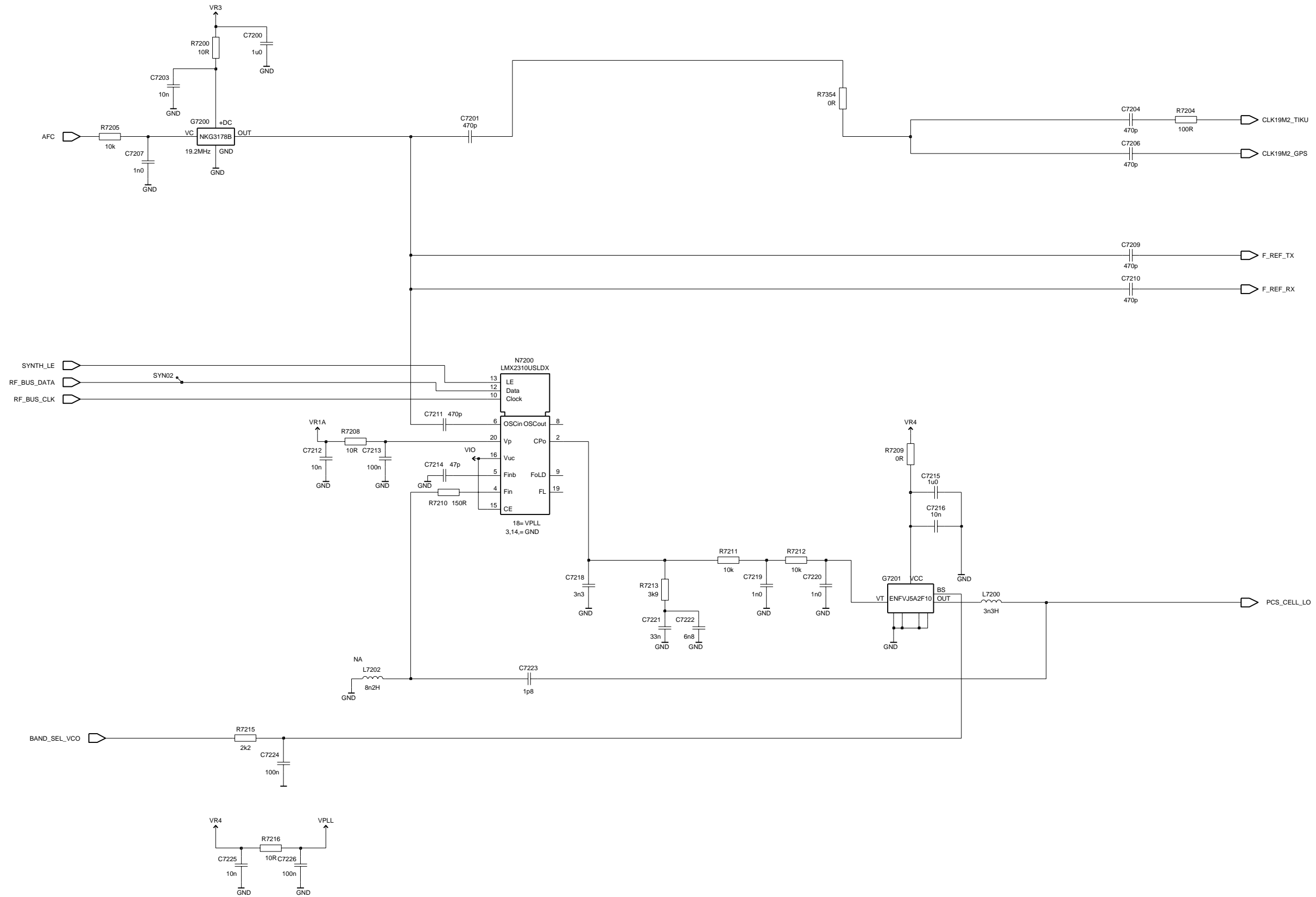

UEME

Version 1, edit 260

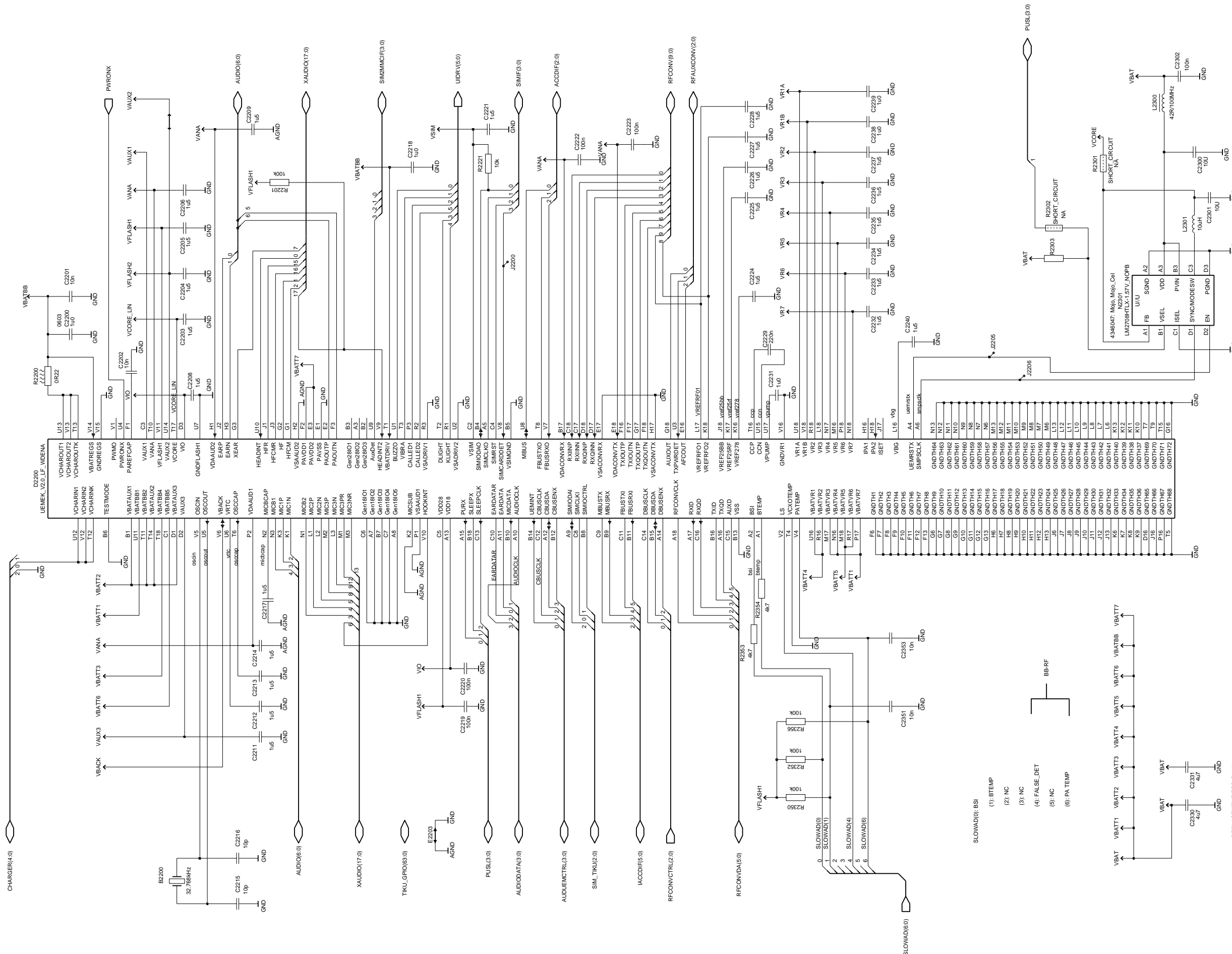

USE 4346047 #TKU2 USED ON SHEET 10

N7000 Tx Upconverter

Version 7.5, edit 117

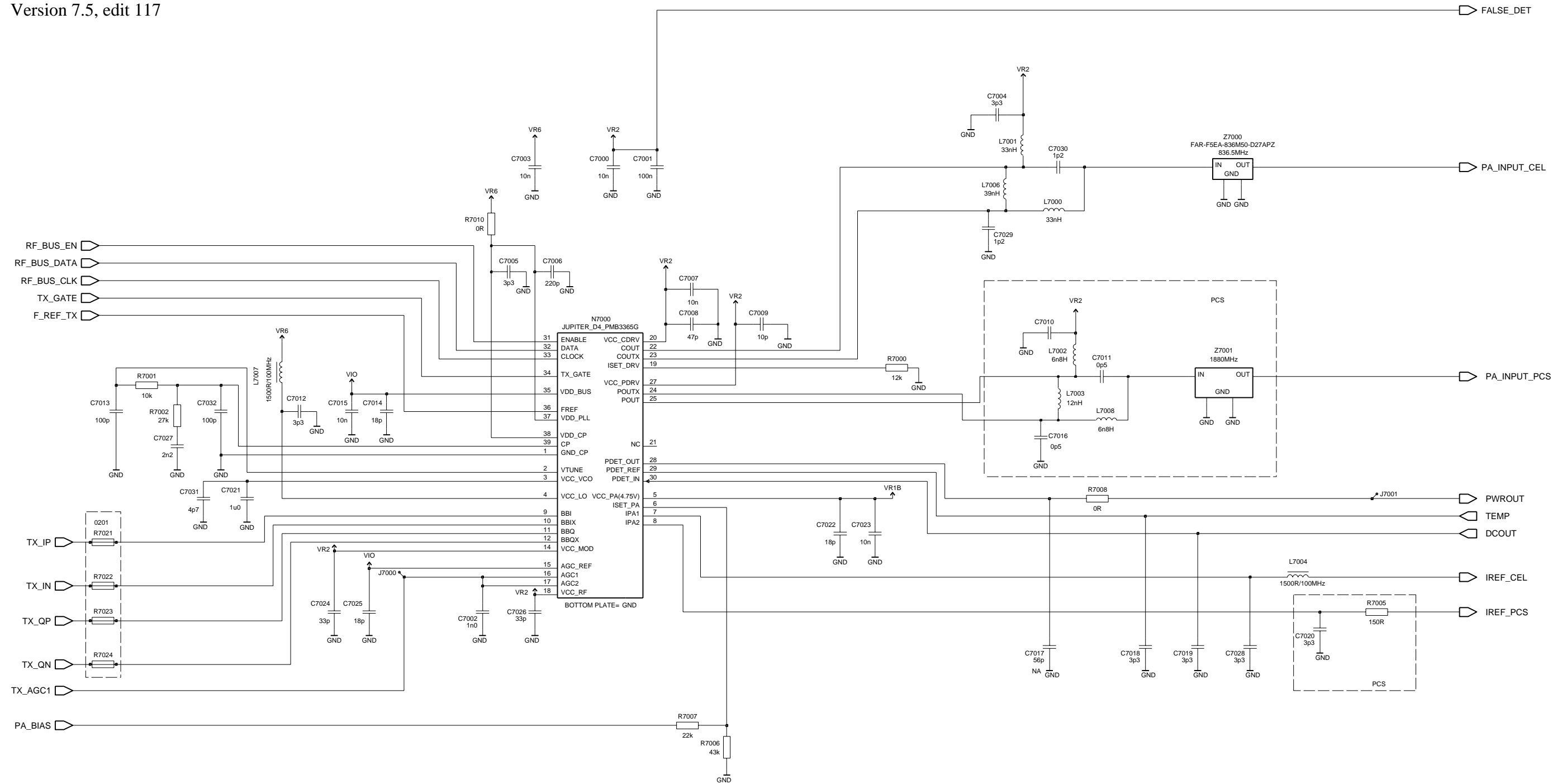

FM Radio

Version 1.3, edit 205

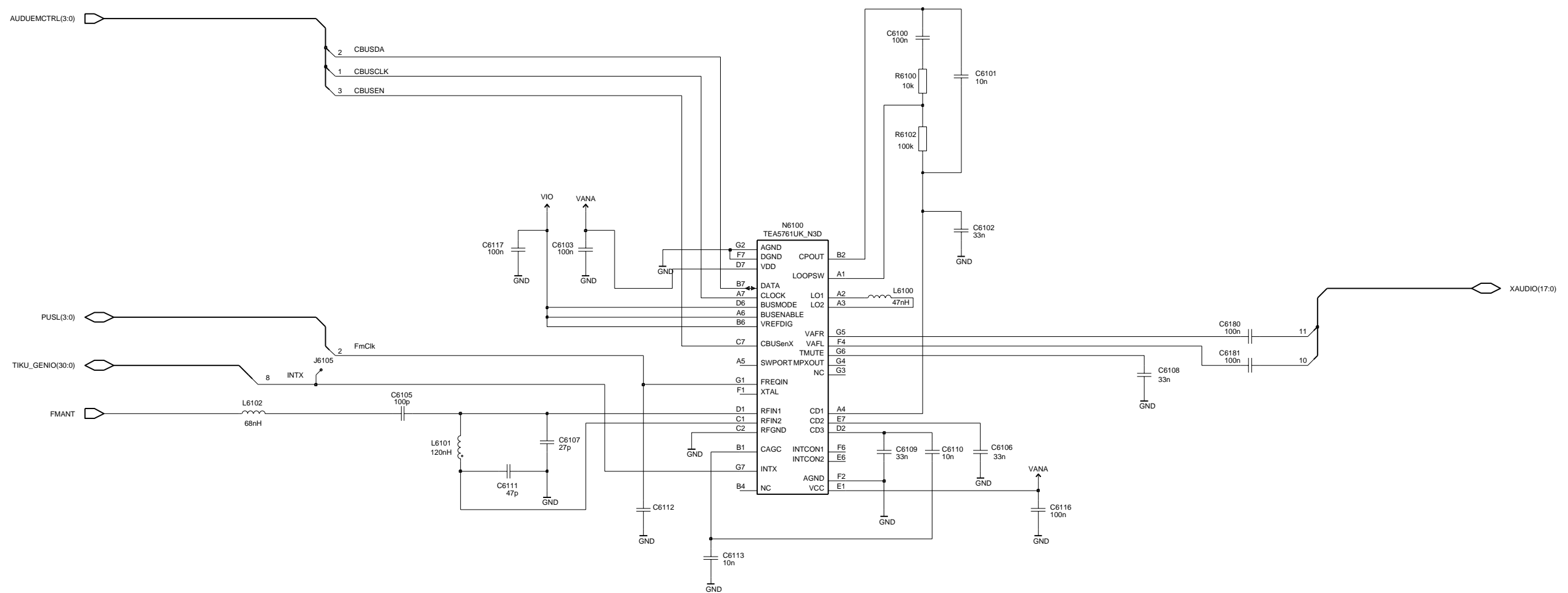

UI PWB Top Level

Version 0.5, edit 158

FLEX CONNECTOR LCD PWB

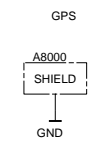
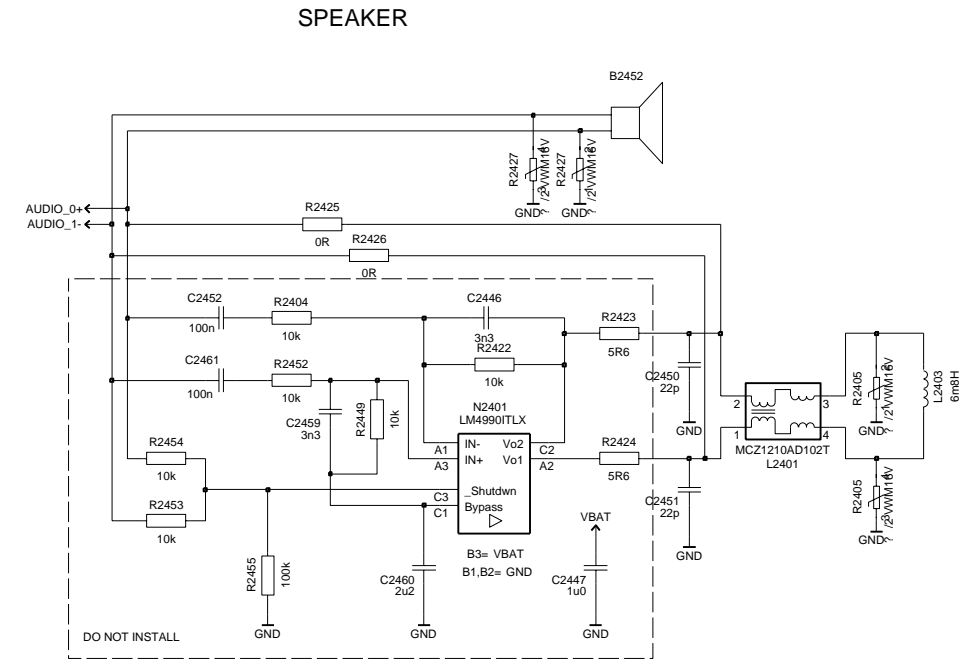
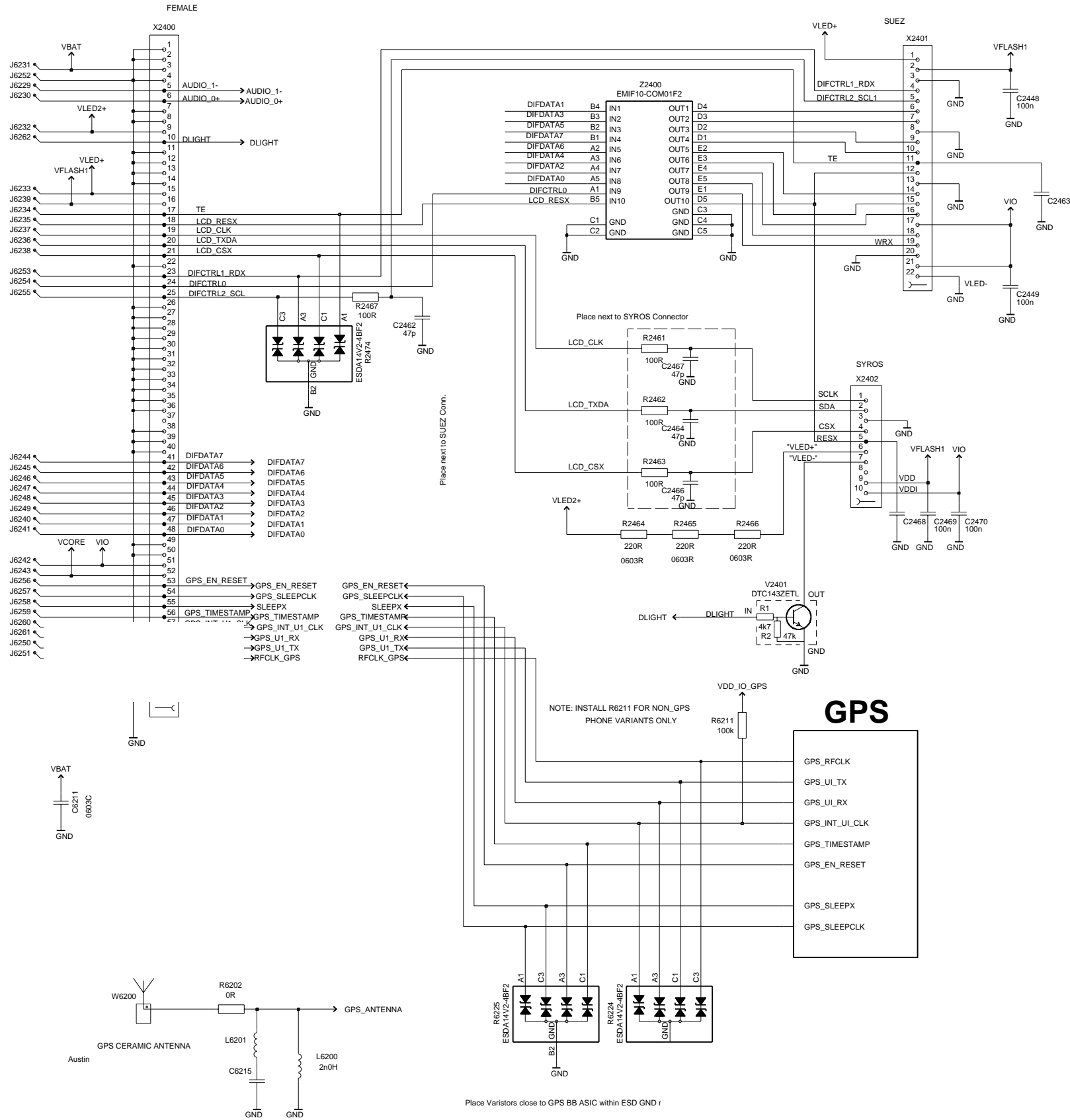

3155i GPS RF

Version 7, edit 141

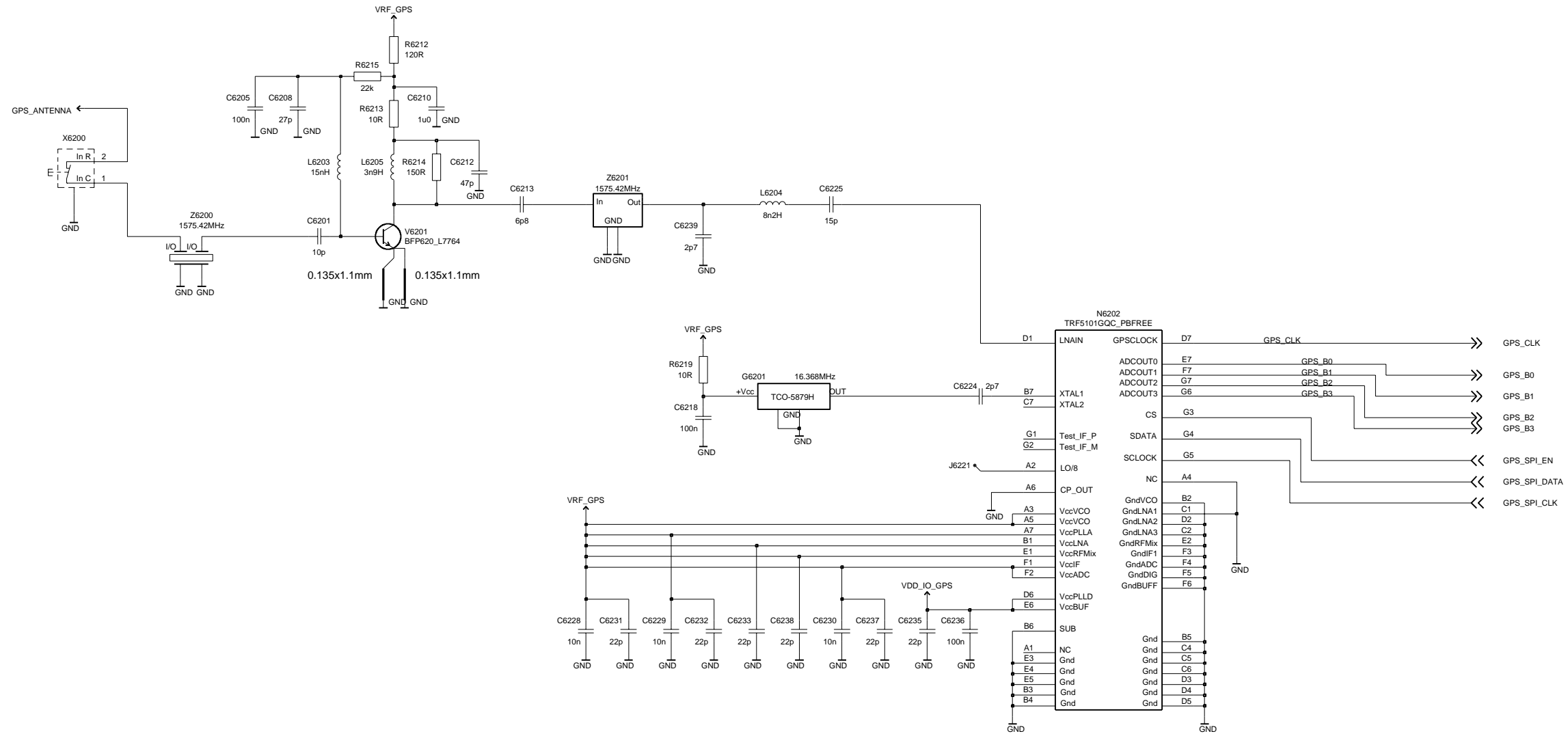

3155i GPS BB

Version 7, edit 191

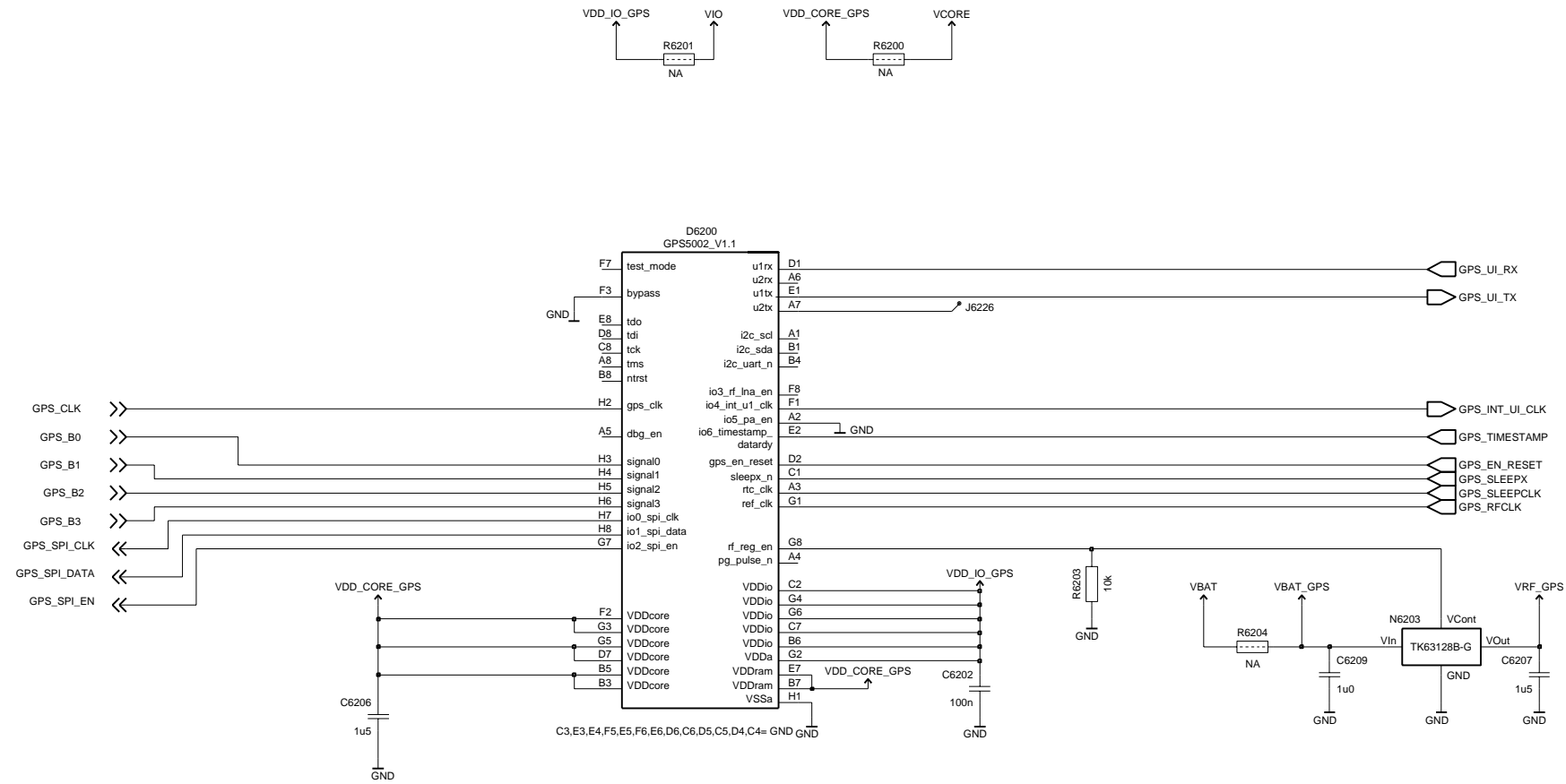

Make an ESD GND moat around the GPS module

Flex Interface

Version 0.0, edit 150

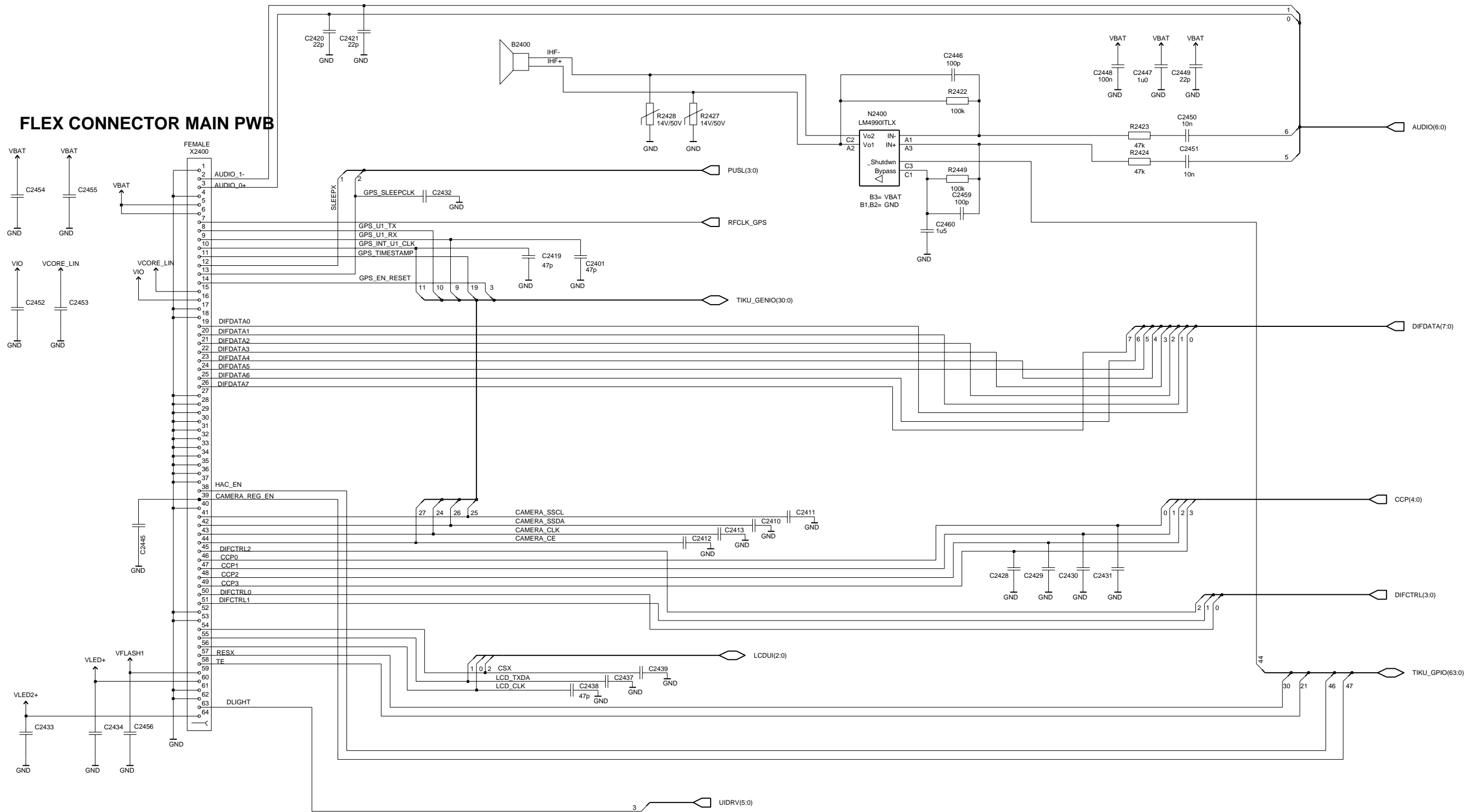

Note: Camera signals are not applicable to the 3155/3155i (RM-41) and 3152 (RM-61) mobile terminals

3152 Component Layout - Bottom

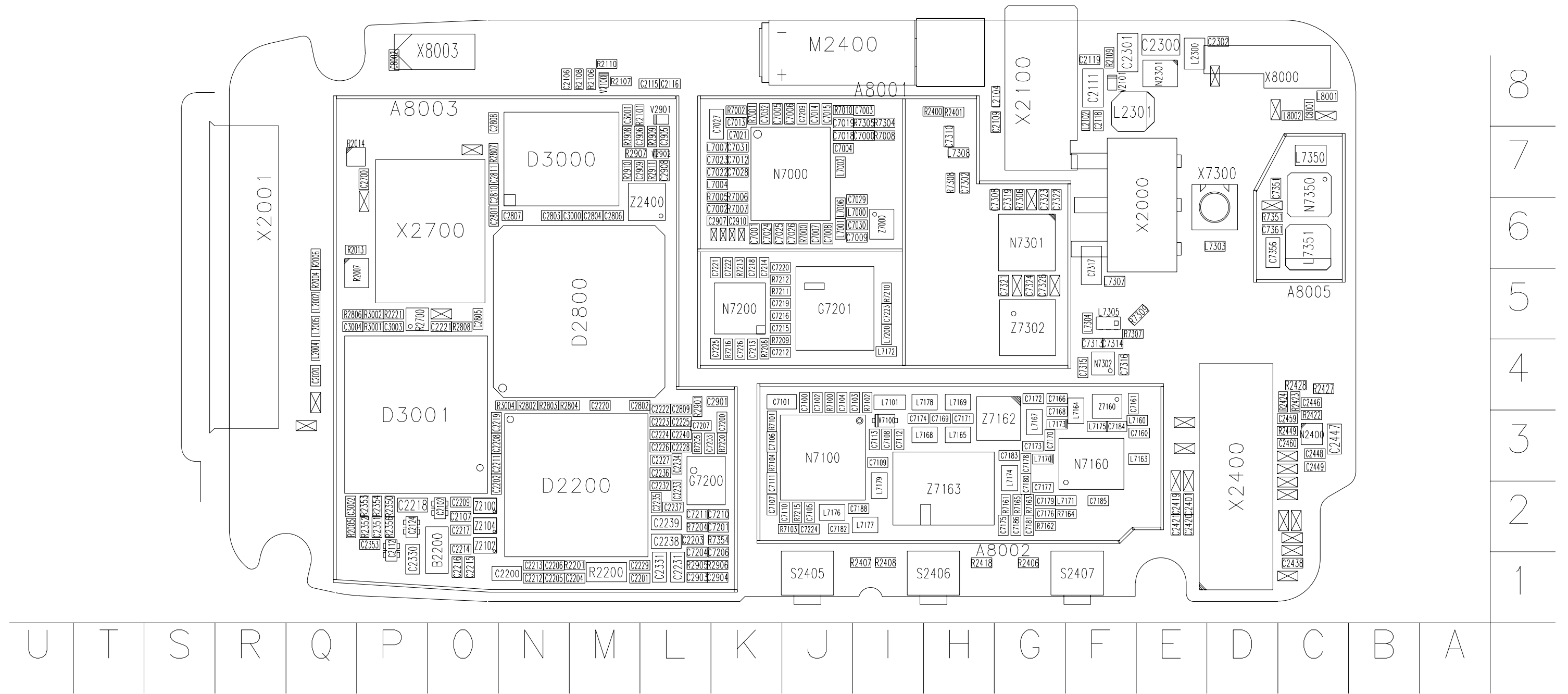

3155 and 3152 (Non-GPS) Component Layouts and Values — Secondary Display

3155 and 3152 Component Layout - Top

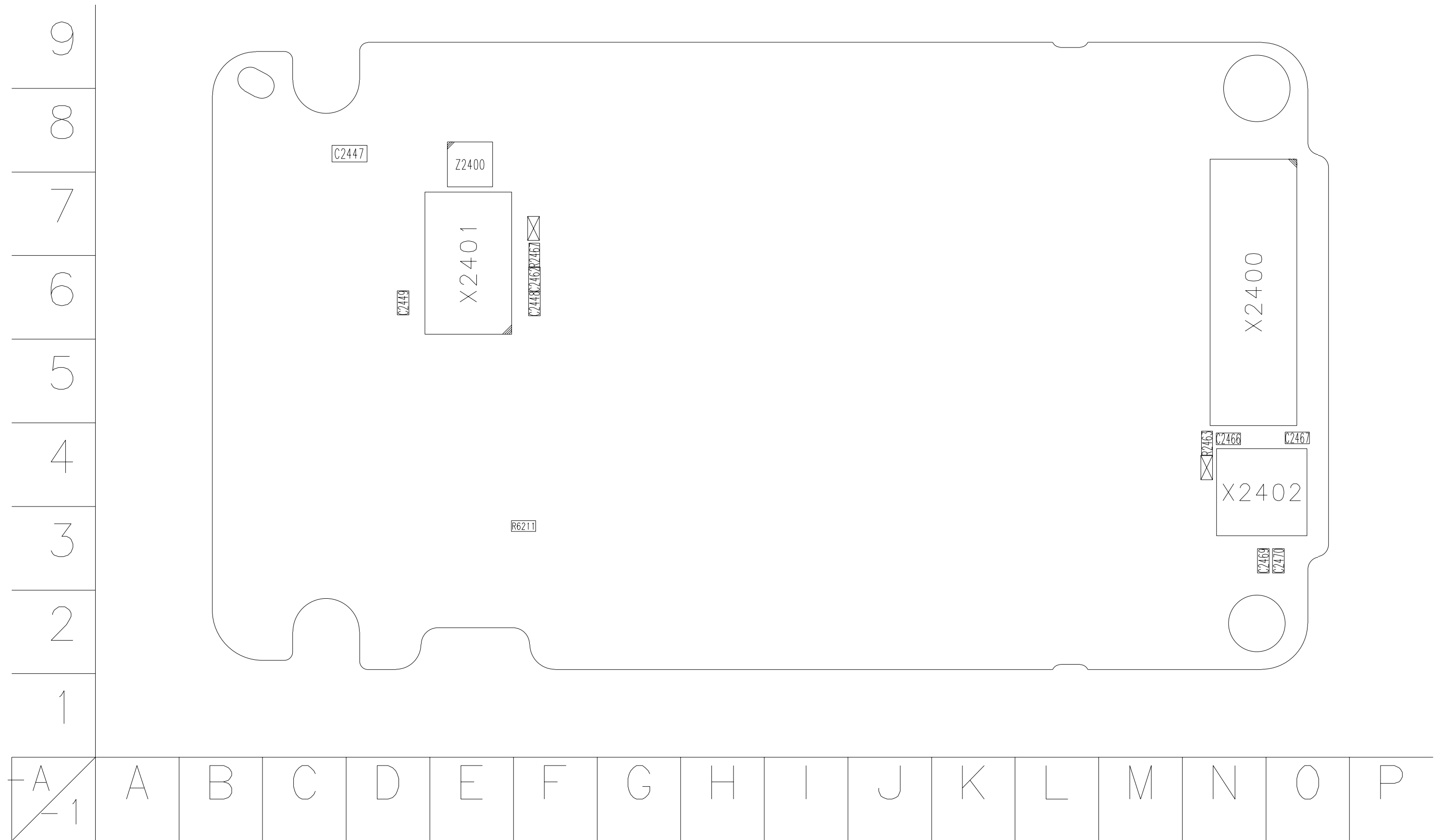

3155 and 3152 Component Layout - Bottom



9
8
7
6
5
4
3
2
1

P	O	N	M	L	K	J	I	H	G	F	E	D	C	B	A	A
---	---	---	---	---	---	---	---	---	---	---	---	---	---	---	---	--------------

3155i (GPS) Component Layouts and Values — Secondary Display

3155i Component Layout - Top

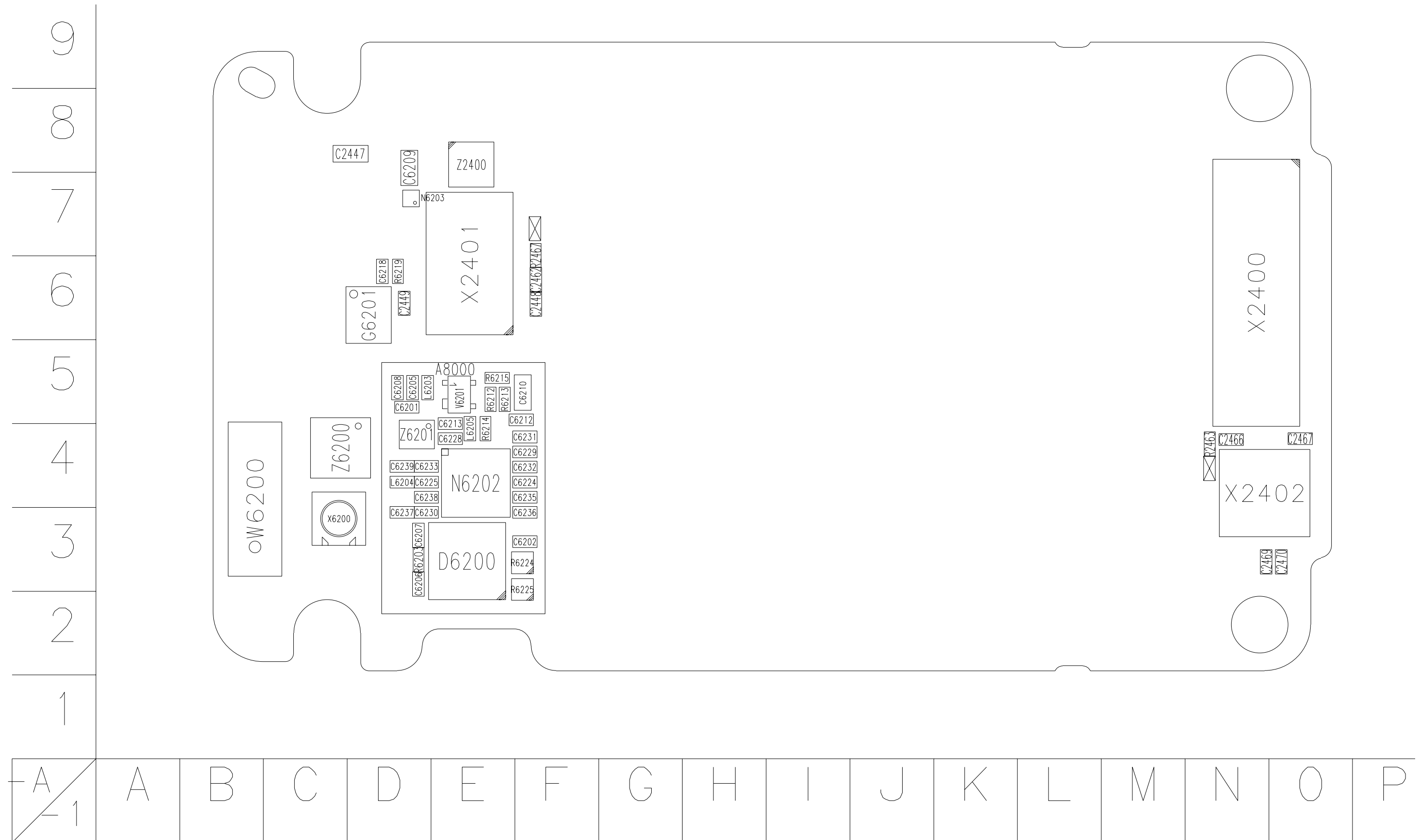

3155i Component Layout - Bottom

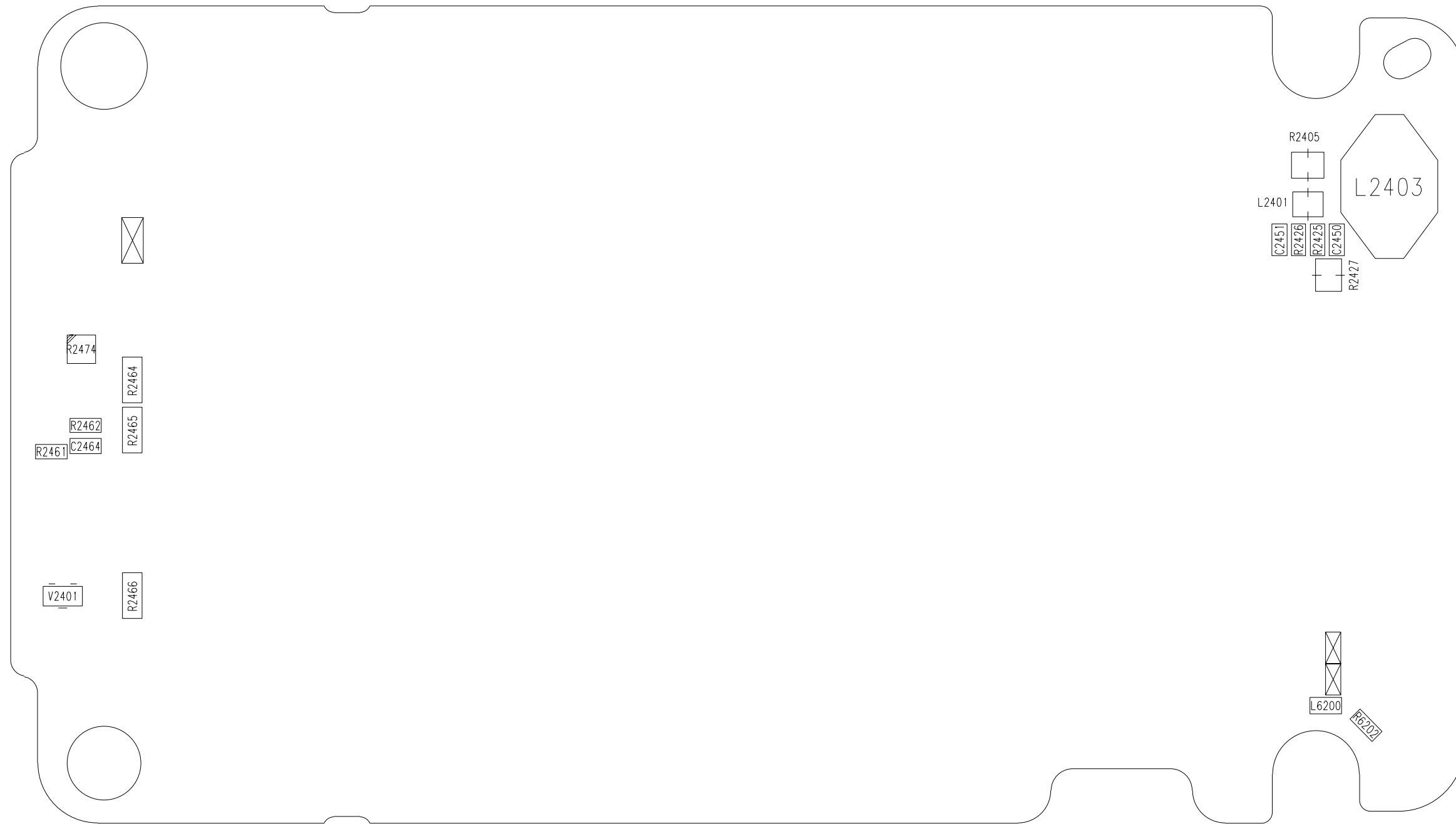

9
8
7
6
5
4
3
2
1

P	O	N	M	L	K	J	I	H	G	F	E	D	C	B	A	A
---	---	---	---	---	---	---	---	---	---	---	---	---	---	---	---	--------------

This page intentionally left blank.